

# ManSafe® for Industry

Fall protection systems  
for industrial applications

- Overhead Systems
- Horizontal Systems
- LadderLatch™
- VersiRail®
- Self Retracting Lifeline (SRL)



# Fall protection matters



Falls from height are the single biggest cause of death and one of the biggest causes of serious injury in the workplace today. For businesses whose workers need to operate quickly and effectively at height, fall protection is already a major issue—and this will become increasingly important as specific legal measures continue to be introduced worldwide such as OSHA in the United States and the Temporary Working at Height Directive in Europe. These measures include;

- Where fall protection is needed
- Which systems are acceptable
- Who is responsible

Whether companies or individuals, those who instruct or allow operatives to work at height have a clear responsibility for their safety—including aircraft owners and managers.

## Are you responsible?

The answer could well be 'Yes'. According to the health and safety legislation these people are 'duty-holders'—responsible for ensuring adequate fall protection and potentially liable in the event of an accident.

## What you need to do

The official advice to duty-holders can be summarised as follows:

- Avoid work at height, where possible
- When working at height is essential, ensure that workers are not exposed to unnecessary risks
- Where it is not possible to eliminate the risk of falling, **use a suitable fall protection system to minimise the consequences of a fall**



**Latchways plc—global leaders in fall protection**



# ManSafe for Industry

## Fall protection for industrial applications

### Overhead System

Latchways' overhead systems combine revolutionary Constant Force® technology with an innovative mobile anchorage in a robust solution that offers outstanding levels of safety, convenience and versatility in virtually any industrial environment.

Workers attached to the overhead system enjoy both unfettered mobility and continuous, hands-free security whilst working at height.

### Safety

- System tested to EN 795
- Mobile anchorage certified by SATRA
- Conforms to EN 362:1992
- System uses 1 x 19 stainless steel Ø 8 mm cable. This has low stretch properties and has a breaking strain of over 45 kN
- In-line Constant Force energy absorber ensures that the maximum load on the worker and end anchor in the event of a fall does not exceed 18 kN
- System cable is tensioned to 5 kN to prevent cable sag and possible whiplash in the event of a fall
- Mobile anchorage glides freely through intermediate cable guides allowing mobility of the worker at different angles for continuous hands-free protection

### Ease of installation and use

- Quick and simple installation
- Suitable for virtually all industrial environments—warehouses, loading bays for example
- Less costly to install than 'I' beam systems
- Can be configured as a single span (up to 60 m) or multi-span system
- Can be used by up to three workers
- Mobile anchorages remain permanently attached to system
- Can be retrofitted to existing structures or incorporated at the design stage of new facilities
- Easily able to accommodate changes of direction
- Written warranty available on service life of system



# Overhead—Single and Multi-Span systems

## Single span system

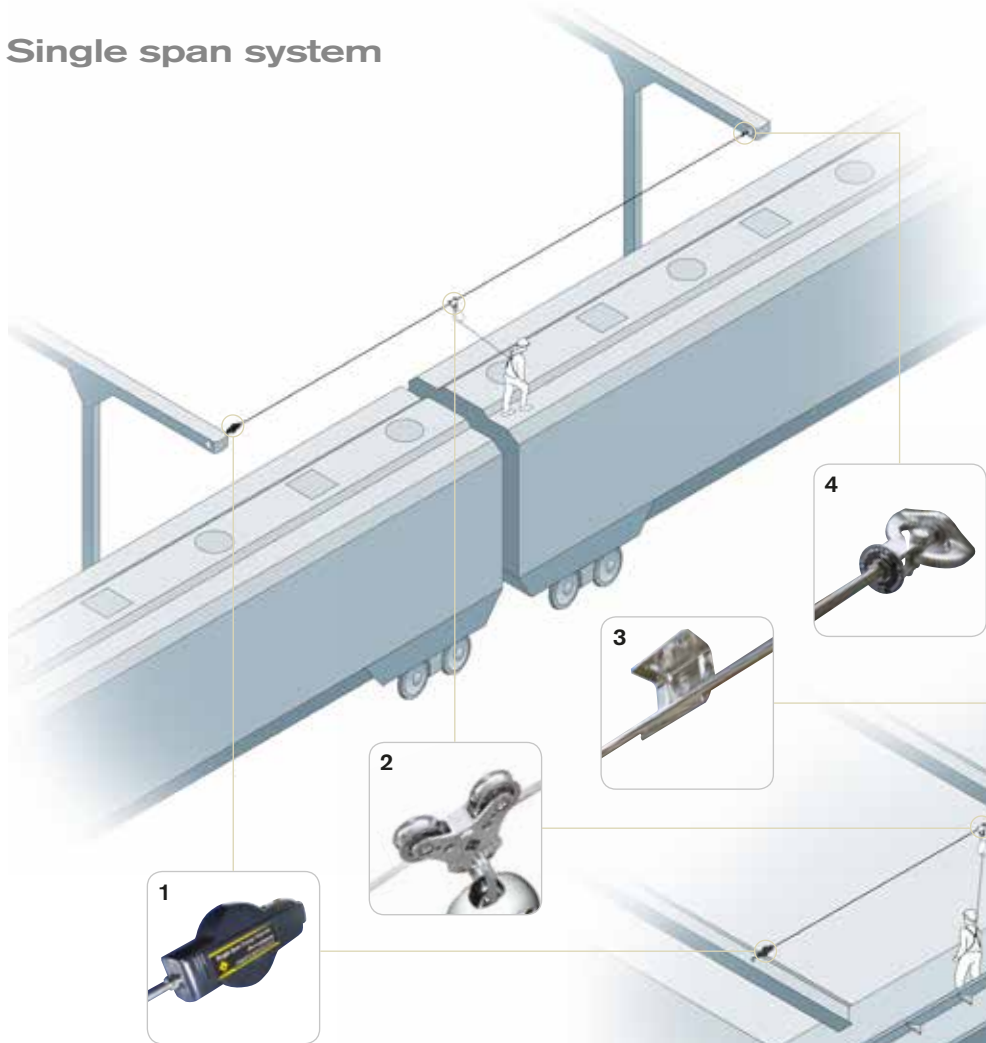

Typical uses of overhead systems illustrated: rail car loading bay and internal factory access.

## Multi-span system

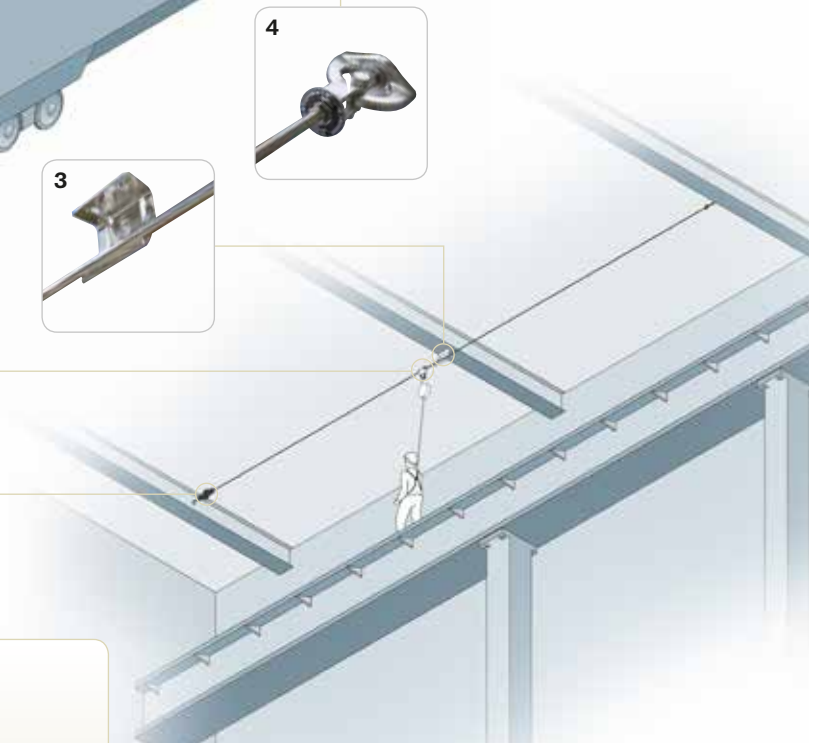

### Components

#### 1 Constant Force Energy Absorber

Located at one end of the system, the energy absorber ensures that the maximum load transferred to the structure in the event of a fall does not exceed 18 kN.

#### 2 Overhead System Mobile Anchorage

Connects the user via a SRL (Self Retracting Lifeline) to the overhead fall protection cable.

#### 3 Intermediate Brackets

Support the cable on multi-span systems and also accommodate change in direction.

#### 4 Line Tensioning Device

Allows the system to be correctly tensioned for use. The indicator disc will spin freely when the correct tension is reached at 5 kN.

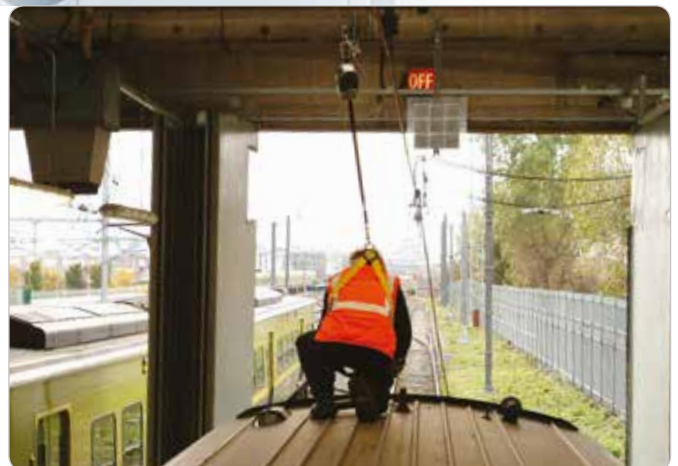



# ManSafe for Industry Self Retracting Lifeline

Latchways has combined innovative engineering, superior materials and futuristic design with quick and easy maintenance to provide the most advanced range of Self Retracting Lifelines (SRL) on the market.

The range is designed for use with the ManSafe overhead single and multi-span systems—providing the complete solution for overhead industrial fall protection.

The ManSafe Sealed SRLs have been specifically designed for use in harsh marine environments such as on offshore wind turbines and oil rigs. Their inherent flexibility means the device can be installed on even the most complex structure for unhindered hands-free fall protection.

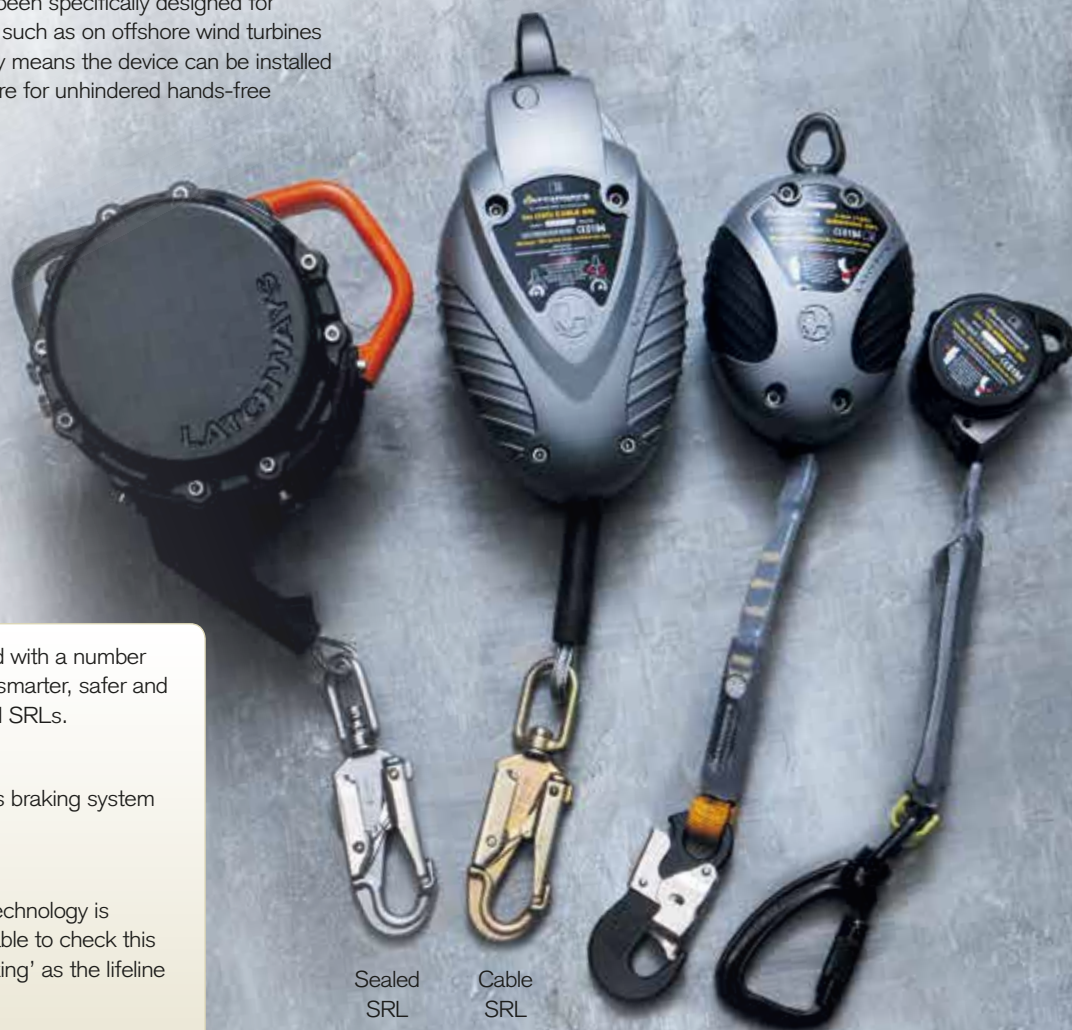

Sealed  
SRL

Cable  
SRL

Webbing  
SRL

Mini SRL

The SRLs have been developed with a number of unique features to provide a smarter, safer and stronger alternative to traditional SRLs.

## Smarter

Latchways' patented frictionless braking system won't go out of adjustment.

## Safer

The advanced Full Contact™ technology is 100% reliable, the user being able to check this by feeling and hearing the 'clicking' as the lifeline extends and retracts.

## Stronger

Impact resistant cases are manufactured to protect the SRLs and the internal components from damage.

## Better

Modular design allows quick and easy servicing of the SRL, facilitating the opportunity for either in-house, or third party, service personnel to conduct the service ensuring minimal 'downtime'.

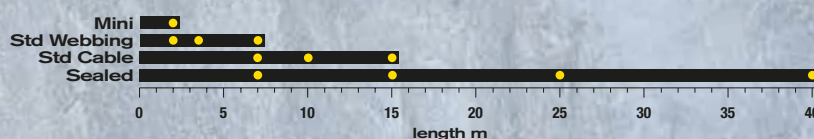

# Solutions for any situation

As you would expect from the global leader in fall protection systems, Latchways' product range is designed for use in a wide variety of industrial applications. Horizontal, LadderLatch™ and VersiRail® systems are as versatile and durable as the overhead solutions with the advantage that they can be used in situations where overhead systems are inappropriate.



## Horizontal systems

Latchways' horizontal systems are built around the innovative Transfastener™ and patented Constant Force technology, which provide continuous hands-free security and guarantee unrivalled fall protection. The system range is inherently flexible using 7 x 7 Ø 8 mm stainless steel cable with a variety of in-line components and can be designed for up to five simultaneous users. Suitable for use on virtually any type of structure or roofing arrangement, it can be specified as a single cable system or a multi-faceted system that follows the contours of the structure being worked on.

## VersiRail

The VersiRail guardrail provides a comprehensive collective protection solution for worker safety at height. There are four style variations available as a non-penetrative self-weighted system or alternatively with a choice of fixing plates. It is quick and easy to install and can be used on virtually any flat surface.

## LadderLatch systems

The Latchways LadderLatch system can be fitted to any type of fixed industrial ladder and installed to follow the contours of any structure it is attached to, thereby maximising user safety. As with the horizontal systems, the LadderLatch solution employs Latchways' Transfastener and Constant Force technologies to provide hands-free security and industry-leading fall protection. LadderLatch systems can be installed as part of a new build or retrofitted and are suitable for use by up to four workers at a time.



# ManSafe for Industry

## Why choose Latchways?

With over 30 years experience and a worldwide installer network, Latchways is the global leader in fall protection. Latchways revolutionised fall protection with its patented Transfastener and Constant Force technologies and continues to innovate, with new products being designed and manufactured specifically for use across different industrial environments.

### Engineering excellence

All Latchways systems are manufactured to the highest international standards, using only the best materials.

System components are individually numbered, batch conformance and dye penetrant tested—a quality standard unsurpassed in the industry.

In addition to rigorous in-house testing, all Latchways products undergo external verification to ensure they meet or exceed the relevant industry standards. Latchways products are specifically developed to take account of the latest structural innovations. The company's commitment to excellence means that its systems have a proven track record of safety and reliability—even in the most extreme environments.

### Standards

The key standards relating to fall protection systems for use in industrial environments are:

- EN 353-1 Personal Protective Equipment (PPE) against falls from a height—Specification for guided type fall arresters on a rigid anchorage line
- EN 353-2 PPE against falls from a height—Guided type fall arresters including a flexible anchor line
- EN 341 PPE against falls from a height—Descender devices
- EN 354 PPE against falls from a height—Lanyards
- EN 355 PPE against falls from a height—Energy absorbers
- EN 358 PPE for work positioning and prevention of falls from a height—Belts for work positioning and restraint and work positioning lanyards
- EN 360 PPE against falls from a height—Retractable type fall arresters
- EN 361 PPE against falls from a height—Full body harness
- EN 362 PPE against falls from a height—Connectors
- EN 363 PPE against falls from a height—Fall arrest systems
- EN 364 PPE against falls from a height—Test methods
- EN 795 PPE against falls from a height—Anchor devices. Requirements and testing





## ManSafe®

This brochure is prepared for general information only and should not be relied upon in any specific situation without appropriate technical and legislative advice. Whilst every effort has been made to ensure the content of this brochure it may contain inaccuracies or errors, and we expressly exclude liability for any such inaccuracies or errors to the fullest extent permitted by law. If you require any further advice on any of the issues contained herein please contact a member of our technical team.

ManSafe®, Constant Force® and VersiRail® are registered trademarks of Latchways plc  
Transfastener™, LadderLatch™ and Full Contact™ are trademarks of Latchways plc  
Images shown are for visual purposes only, hook configuration may vary by industry